

Anchor Electric Piston Pump[®]

MODEL 101: Steady flow to 800 feet

For well casing of 2 in. or more

The Anchor Electric is a positive-displacement, reciprocating piston pump. The top-head-drive electric-control motor, mounted above the wellhead, provides linear pumping action from grade through the sucker-rod assembly in the downhole cylinder.

Constant back-forth motion of the rod-attached piston opens and closes the piston's valves to create suction pressure alternatingly between intake and discharge. Fluid enters as suction volume increases and flows out as discharge volume decreases.

Flows remain constant regardless of differential pressures. There is no power in the well or sump itself.

Model 101 removes fluid from a 2-inch or greater diameter well casing to depths of 800 ft. with a 1 HP motor at 50 Hz; 385 ft. with 1/2 HP. The fluid inlet is at bottom of the intake cylinder and removes product to 0 submergence depth. The pump can run dry without damage.

Model 101 is designed for temperatures to 140° F. For hot sites to 250° F, use Blackhawk's High-Temp Electric Piston Pump™.

FLOW vs. Motor Hertz

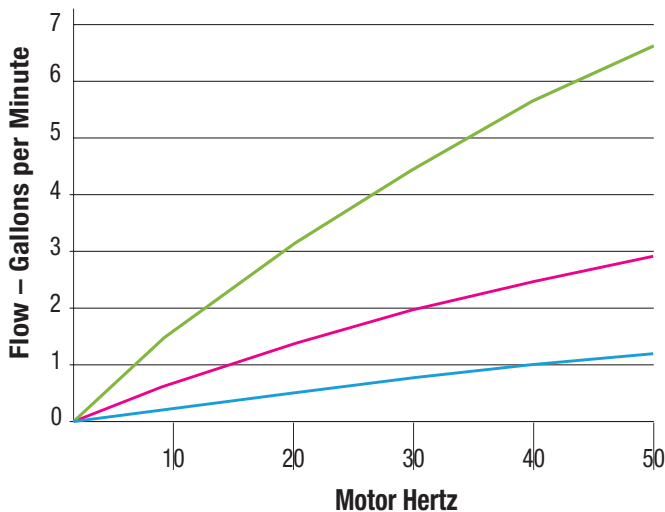

	1.65	3.16	4.47	5.58	6.53
103	1.65	3.16	4.47	5.58	6.53
102	.73	1.4	1.98	2.47	2.89
101	.30	.58	.82	1.02	1.19

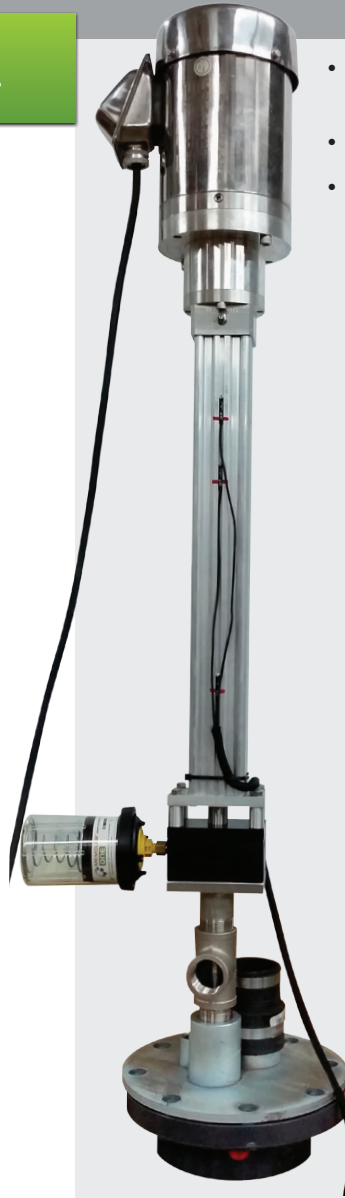

- Operational Depth: To 800 ft. / 240 m. (1 HP); 385 ft. / 117 m. (1/2 HP)
- Flow Range: To 1.2 US gpm / 4.5 lpm
- Well-Casing Size: Min. 2 in. / 5.08 cm.

PUMP DIMENSIONS

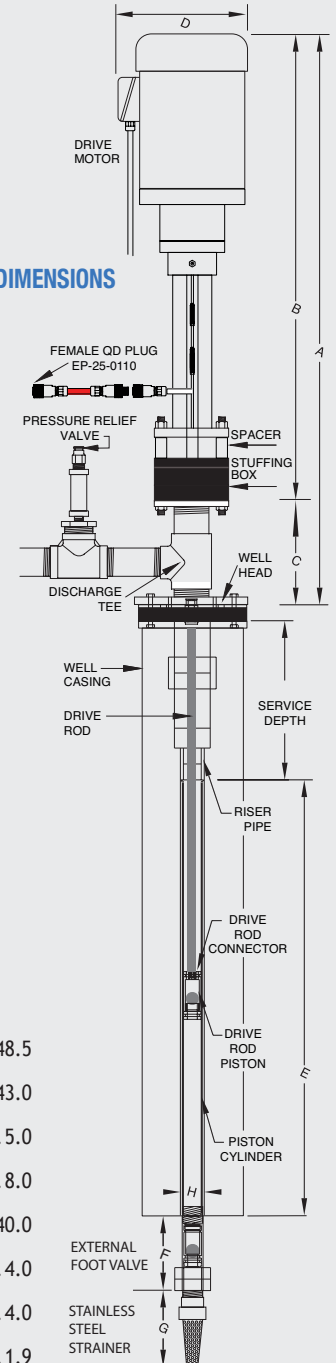

DIMENSIONS (IN INCHES)

- A. Above Well Height 48.5
- B. Driver Length 43.0
- C. Discharge Tee and Well Seal Height .. 5.0
- D. Driver Diameter 8.0
- E. Foot Valve Assembly 40.0
- F. External Foot Valve 4.0
- G. Stainless Steel Strainer..... 4.0
- H. Largest Downhole Diameter 1.9

Anchor Electric Piston Pump®

MODEL 101: Lifts to 800 feet

FLOW vs. DEPTH, 1/2 HP Motor

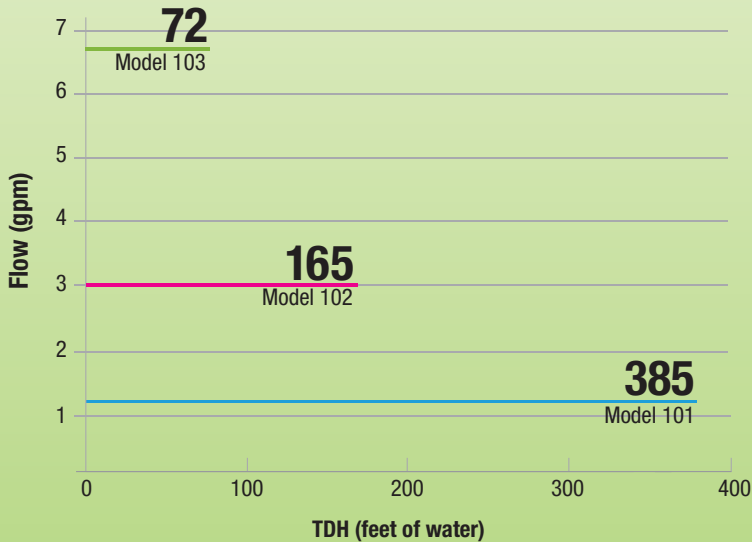

FLOW vs. DEPTH, 1 HP Motor

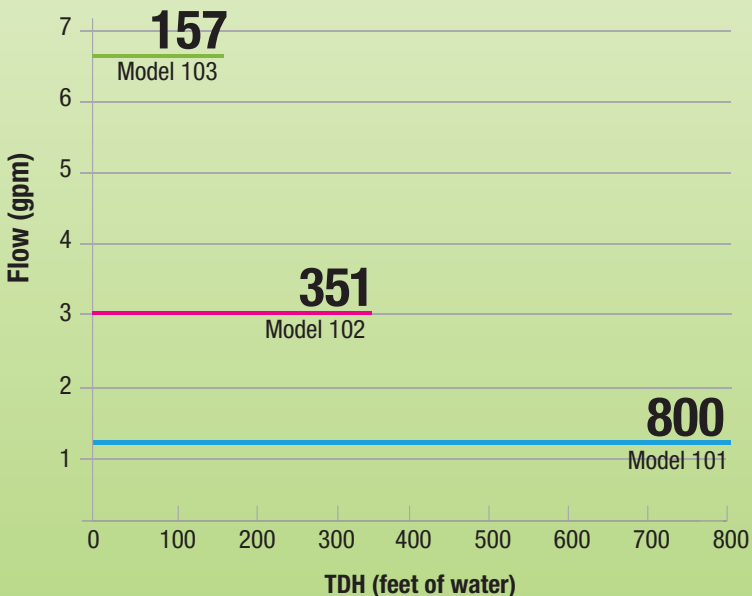

Visit www.blackhawkco.com to see why motors above the wellhead mean less-costly, more compliant, safer operations.

Performance Data

Operating Depth	800 ft., 240 m. (1 HP); 385 ft., 117 m. (½ HP)
Flow Range	To 1.2 US gpm, 1,728 gpd; (½ HP & 1 HP)
Discharge per Stroke	0.068 US gallons per stroke (Flow does not vary with depth)
Motor	½ HP or 1 HP
Power Supply	120- or 230-volt single phase, or 230- or 460-volt three phase
Max. Lift	800 ft., 240 m. (1HP); 385 ft., 117 m (½ HP) *Variable-speed (stroke) control adjusts to well conditions; liquid drawn down to top of strainer
Max. Discharge Pressure	50 psig
Temperature Range	to 140°F / 60°C

Technical Data

Stroke Length	12 in.
Recommended Bore Hole	2 to 3 in. or more
Max External Diameter	2.9 in.
Min Well Casing	2 in.
Cylinder Length	30 in.
Connection to Riser Pipe	1¼ in.
Connection to Sucker Rod	7/16 in - 20 in
Discharge Size	2 in. NPT
Cylinder Weight	8 lb.
Driver Weight	40 lb.
Driver Rod Weight	12 lb. per 100 ft.
Foot Valve Assembly Wt.	8 lb.
Installation	Any angle horizontal to vertical



The best-performing environmental pump in the business